

E1938A Pinout Pictorial

Rick Karlquist, Dec. 10, 2004

Introduction

The E1938A oven crystal oscillator controller board has various configurations for its D-subminiature connector. All configurations use the same PC board with the same physical pin locations, however the connector may be installed on either side of the board, and there are various numbering schemes. This pictorial document shows where various signals are physically located in a photo, to avoid ambiguity with connector pin numbering schemes. Pin numbers in this document are the same as on the schematic.

Component side of board

See figure 1:

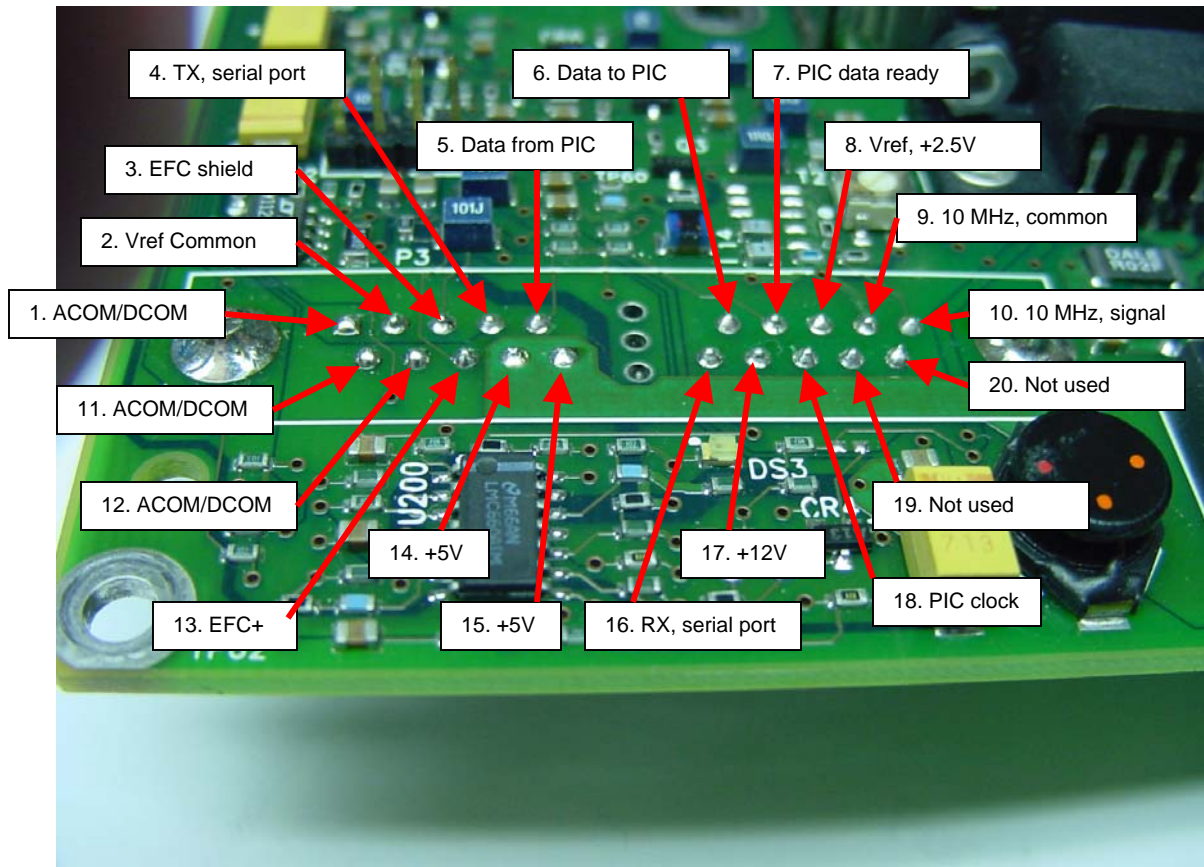

Figure 1. Component side of E1938A controller board.

Circuit side of board

Note that pin numbers are embossed on this connector. See figure 2:

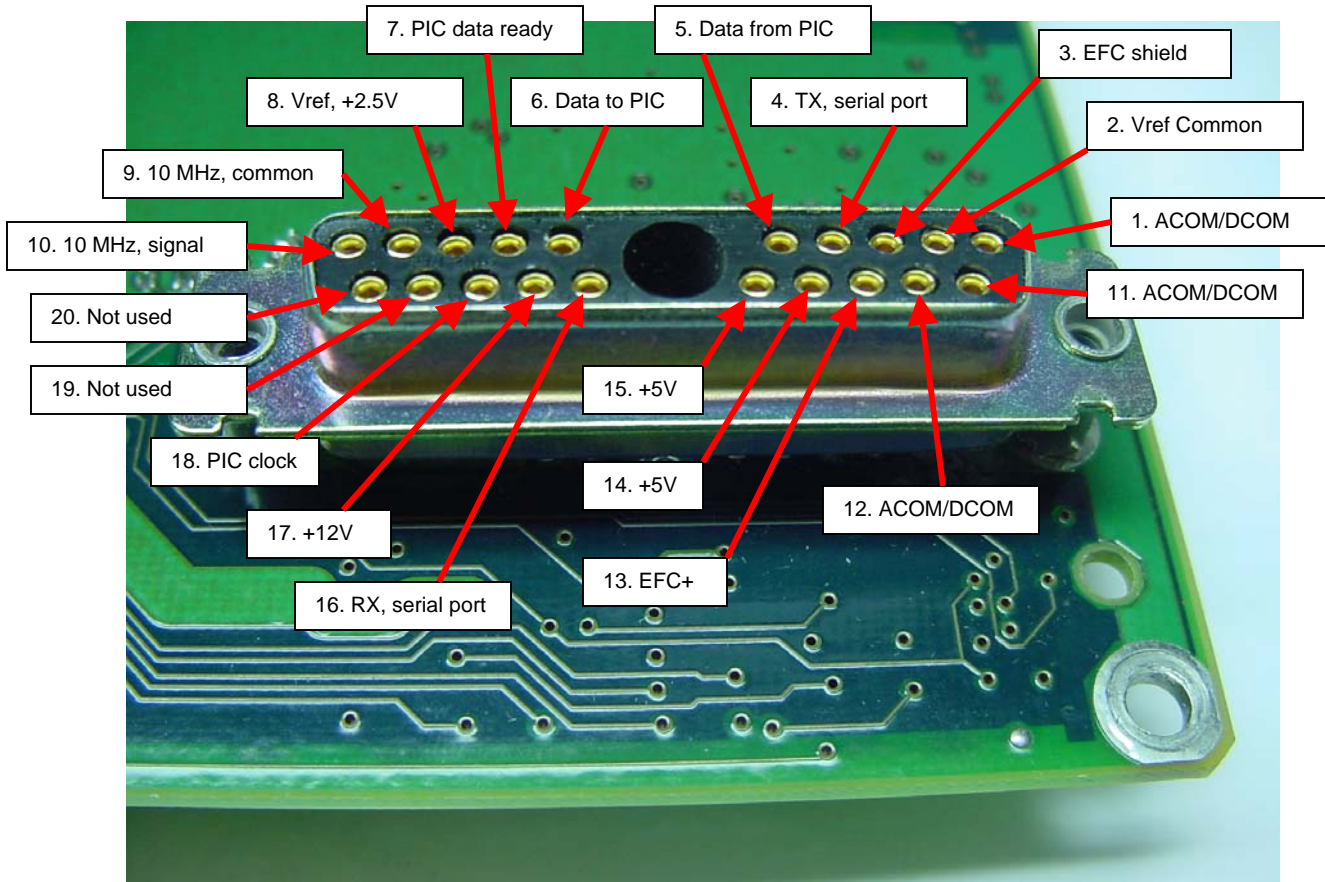

Figure 2. D-sub with coax insert on circuit side of PCB.